

MUTO Comfort L80

Ceiling mount with Dormotion (Wood door)

Installation Manual

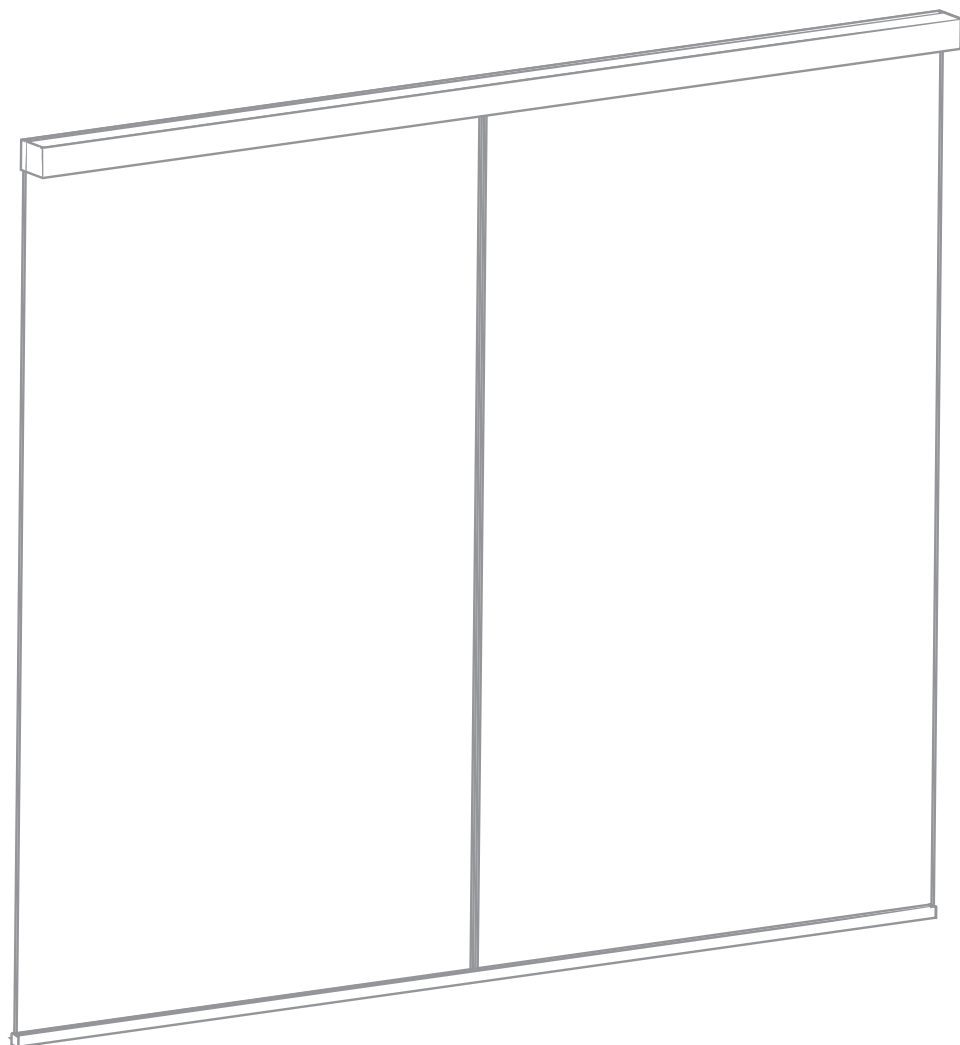

Table of contents

1	Technical specifications	3
1.1	Overview	3
	1.1.1 General information	3
	1.1.2 Intended use	3
	1.1.3 Door requirements and fittings	3
	1.1.4 Safety instructions	3
	1.1.5 Symbols used - Safety/Installation	3
	1.1.6 Maintenance, care, repair	3
	1.1.7 Disposal	3
1.2	Specifications - technical data	3
2	Installation instructions	4
2.1	Overall	4
2.2	Securing wood door adaptor	5
2.3	Securing track to mounting surface	6
2.4	Door/wall dimensions	7
2.5	Installing roller carriers	8
2.6	Install DORMOTION start/stop	9
2.7	Disengaging the anti-jump	9
2.8	Installing the end stops	10
2.9	Install door/rollers in track	10
2.10	Install floor guide	11
2.11	Engaging anti-jump	11
2.12	Adjustment door height	12
2.13	Adjustment end stop location: LEADING end stop	13
	Adjustment end stop location: TRAILING end stop	13
2.14	Install DORMOTION Units	14
2.15	Adjust start/stop pin height (if necessary)	16
2.16	Cover clips	17
2.17	Install brush profile	17
2.18	Install view protection clips	18
2.19	Install cover and view protection profile	19
2.20	Install end caps	19

1 Technical specifications

1.1 Overview

These instructions are for installation of MUTO COMFORT sliding door system L80 for wood doors for the following mounting and style versions:

1. Ceiling mount

1.1.1 General information

- dormakaba glass hardware is not suitable for application in rooms where chemicals (e.g. chlorine) are used as indoor swimming pools, saunas or salt-water pools.
- Never move sliding panels faster than walking speed and always stop the door manually before it reaches end position.
- Do not slide doors with excessive force. Install limiting stop to prevent door from opening too far.

1.1.2 Intended use

- For sliding door in dry indoor areas only
- For manual slowly opening and closing only

1.1.3 Door requirements and fittings

- The substructure/wall must be able to bear permanent loads and be level (max. tolerance: 1/16" [2] per 39" [1m]).
- Fasteners must be sufficiently dimensioned for the substructure/wall and weight of the door.
- When adjusting door components, always stick to the required clearance for the respective hardware.

1.1.4 Safety instructions

- Installation requires two people.
- Only properly qualified and specially trained staff are authorized to mount dormakaba glass hardware.

1.1.5 Symbols used - Safety/Installation



CAUTION

Mounting components must meet the requirements of substructure/wall and door weight. Please read the technical information for fittings.



WARNING



TIPS AND RECOMMENDATIONS

Information note



CLOSING EDGE

1.1.6 Maintenance, care, repair

- Immediately replace damaged parts.
- Always use original dormakaba parts.
- Clean clamping area with alcohol-based standard commercial cleaning agent before mounting the glass hardware.
- Use a damp clothe for occasional cleaning, especially the track.
- Always use silicone - and oil-free cleaners (e.g. acetone).
- Check door hardware at regular intervals for proper positioning and smooth operation and correct adjustment.
- High traffic door systems require inspection by properly qualified staff (specialized companies or installation firms.)

1.1.7 Disposal

Disposal in accordance with local, state and national regulations.

1.2 Specifications - technical data

		Single Door	Double Door
		L80	L80
Ceiling mount	Door leaf weight lbs [kg] *	≤176lbs [≤80]	2 x ≤176lbs [2 x ≤80]

* Including weight of auxiliary hardware.

2 Installation instructions

2.1 Overall

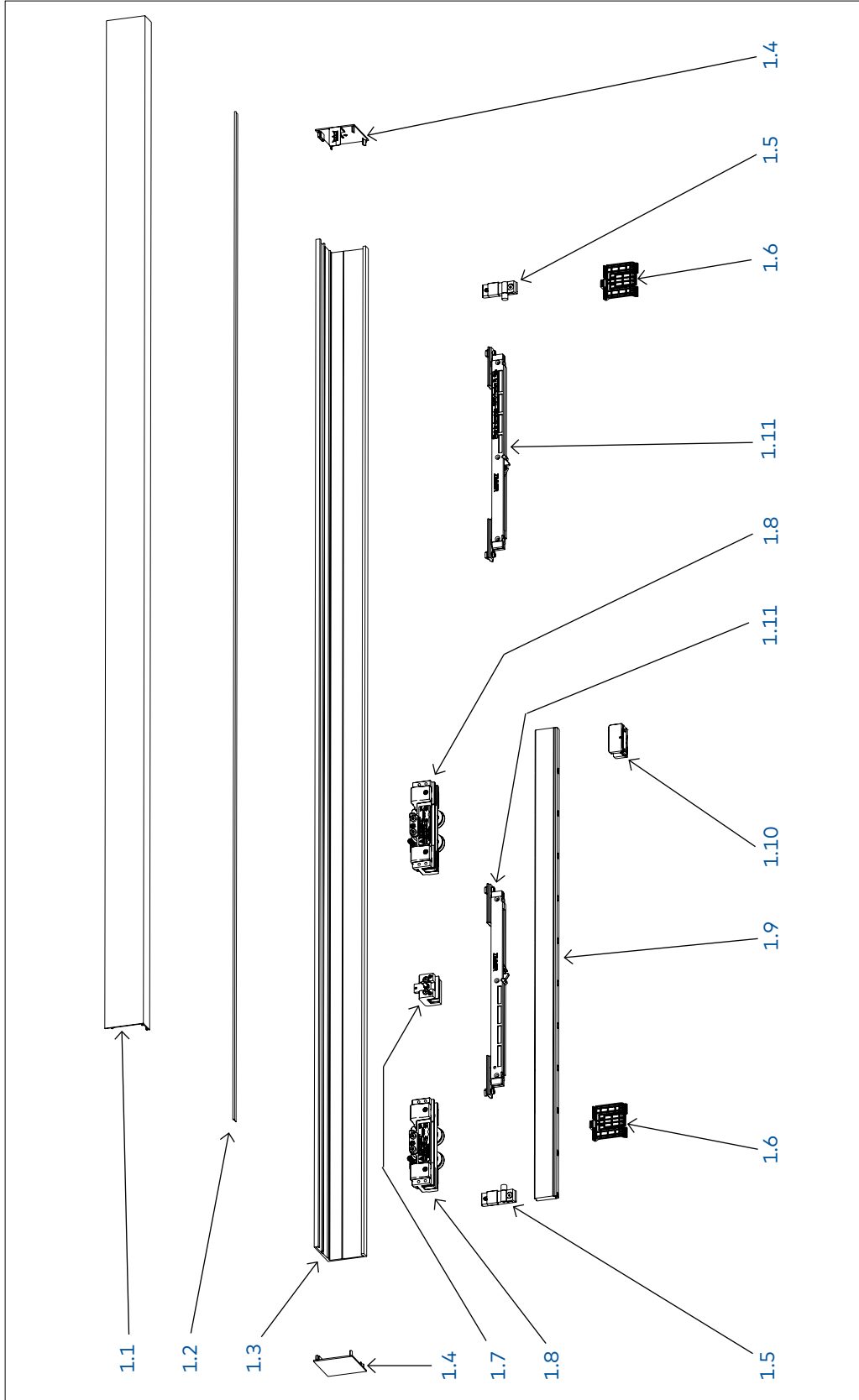

- 1.1 Cover panel
- 1.2 Brush strip
- 1.3 Track
- 1.4 End cap
- 1.5 End stop
- 1.6 Cover clips
- 1.7 Start/stop guide
- 1.8 Roller carrier
- 1.9 Wood door adaptor
- 1.10 Floor guide
- 1.11 Dormotion units

2.2 Securing wood door adaptor

Fig. 1

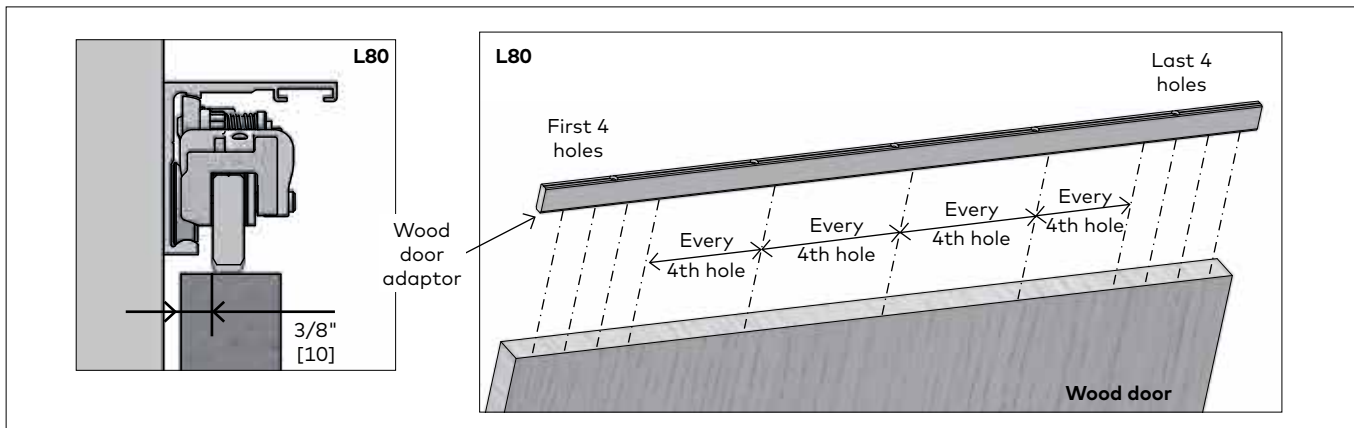

NOTE: Top of door must be reinforced to secure wood door adapter.

2.2.1 Prepare door properly for wood door adaptor.

NOTE: Seal top and bottom of door to minimize warping (use wood door manufacturer's recommendations).

2.2.2 Cut wood door adaptor to be equal width of door.

2.2.3 Secure the two wood door adaptor pieces to top of wood door with #10 x 3" wood screws.

NOTE: Be sure screws are always secured in the first four and last four holes of the adaptor, along with every fourth hole in between.

2.3 Securing track to mounting surface

Fig. 2

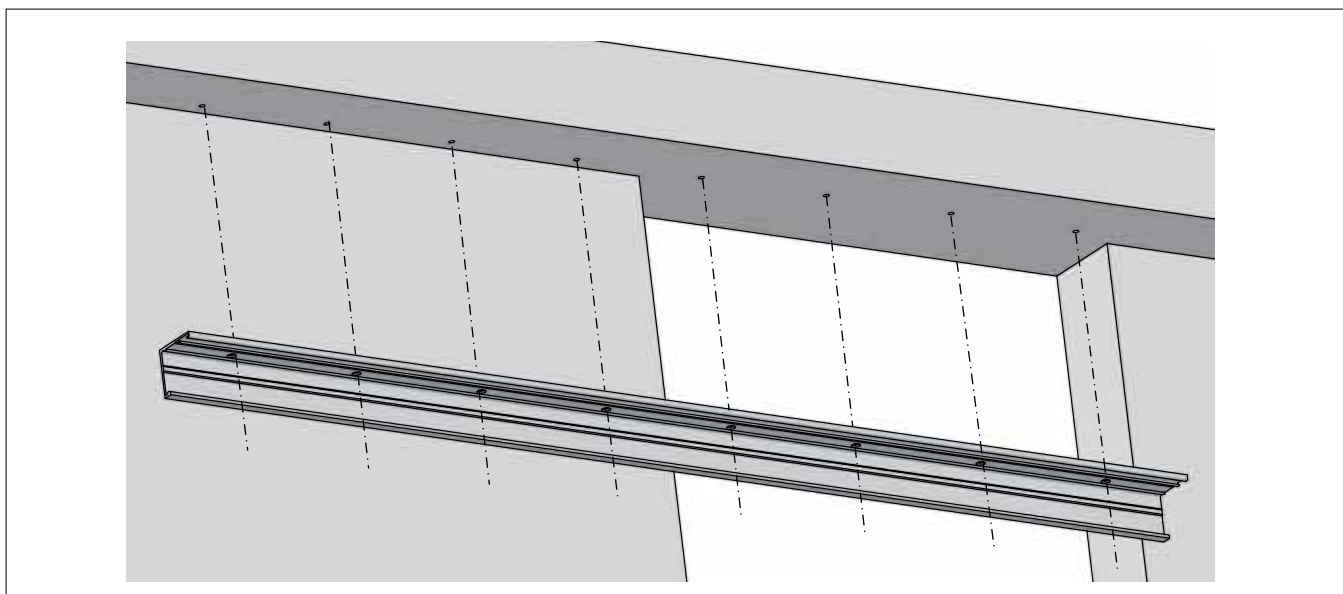

2.3.1 Ensure the track is properly level and secure it to the ceiling per the appropriate measurements on the following page.

- **NOTE: SEE DIMENSION INSTRUCTIONS ON NEXT PAGE FOR REFERENCE.**

NOTE:

OVERHEAD REINFORCEMENT:

The overhead reinforcement must be a minimum of 1/4" [6] x 3" [76] steel angle, 16 gauge metal stud, or two pieces of 1 1/2" [38] thick wood blocking (double stacked), secured to studs or joists on a maximum 16" [406] centers for the length of the track. The overhead reinforcement may be flush on the overhead surface or on the interior of this surface.

2.3.2 Use appropriate fasteners according to the following recommendations.

Track mounting screws must fully penetrate the steel angle, metal stud, or at a minimum of 2" [51] into wood blocking, utilizing the predrilled holes in the MUTO track.

Consult with a structural engineer to determine if reinforcement is adequate for your specific application or to meet specific codes in your location.

2.4 Door/wall dimensions

Single door mount

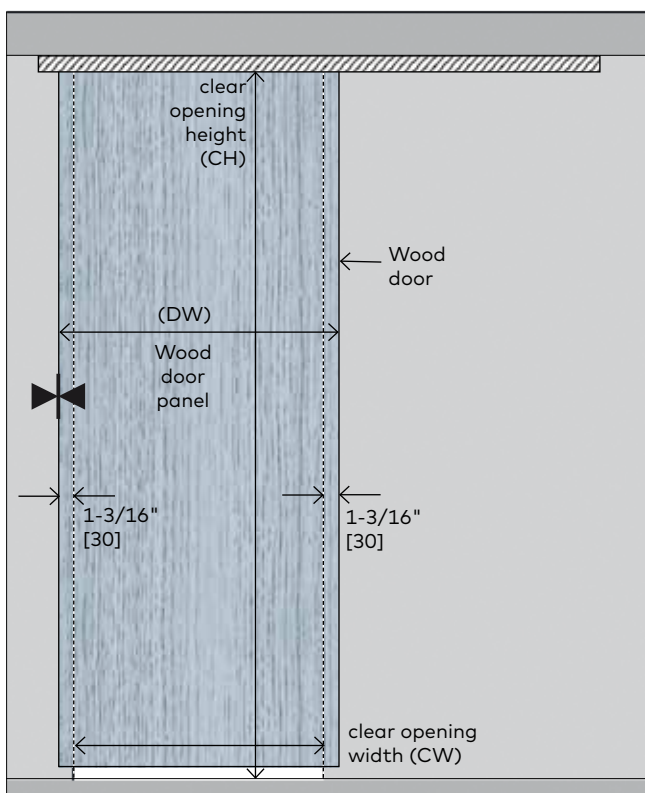

Back of track to center of mounting hole in track

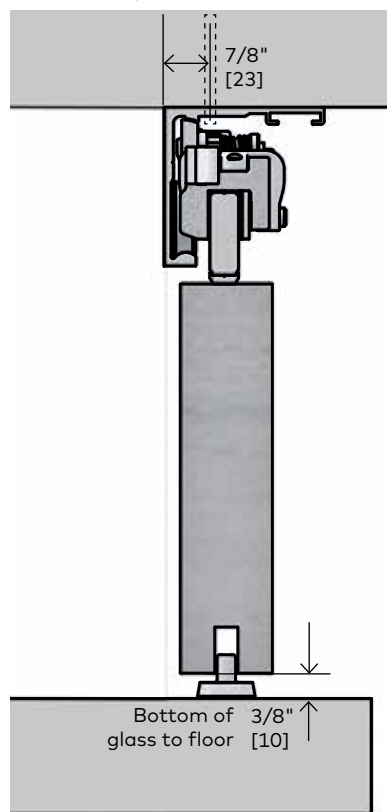

Double door mount

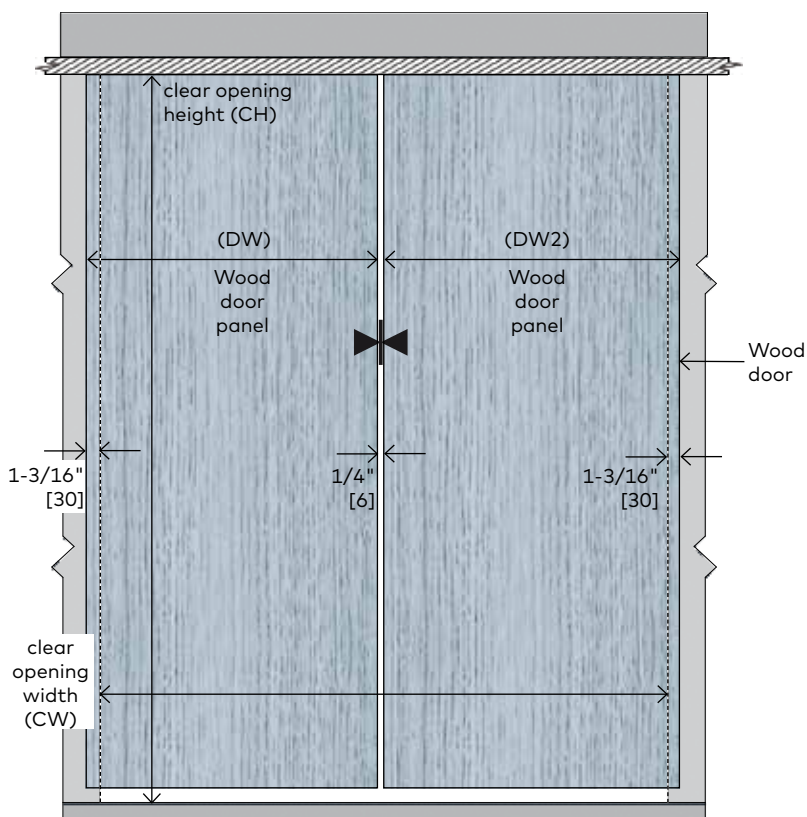

Back of track to center of mounting hole in track

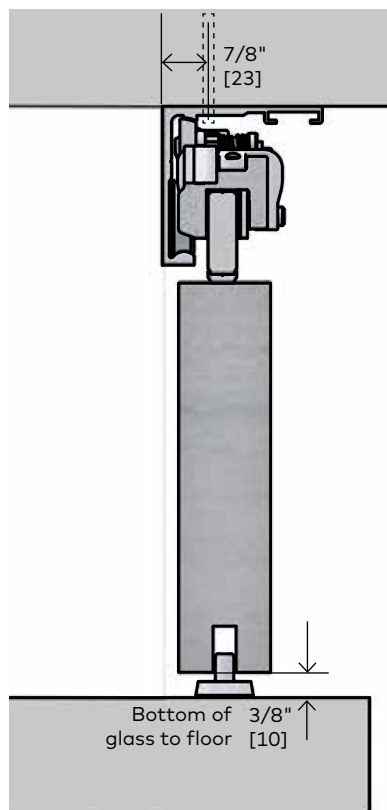

2.5 Installing roller carriers

Fig. 3

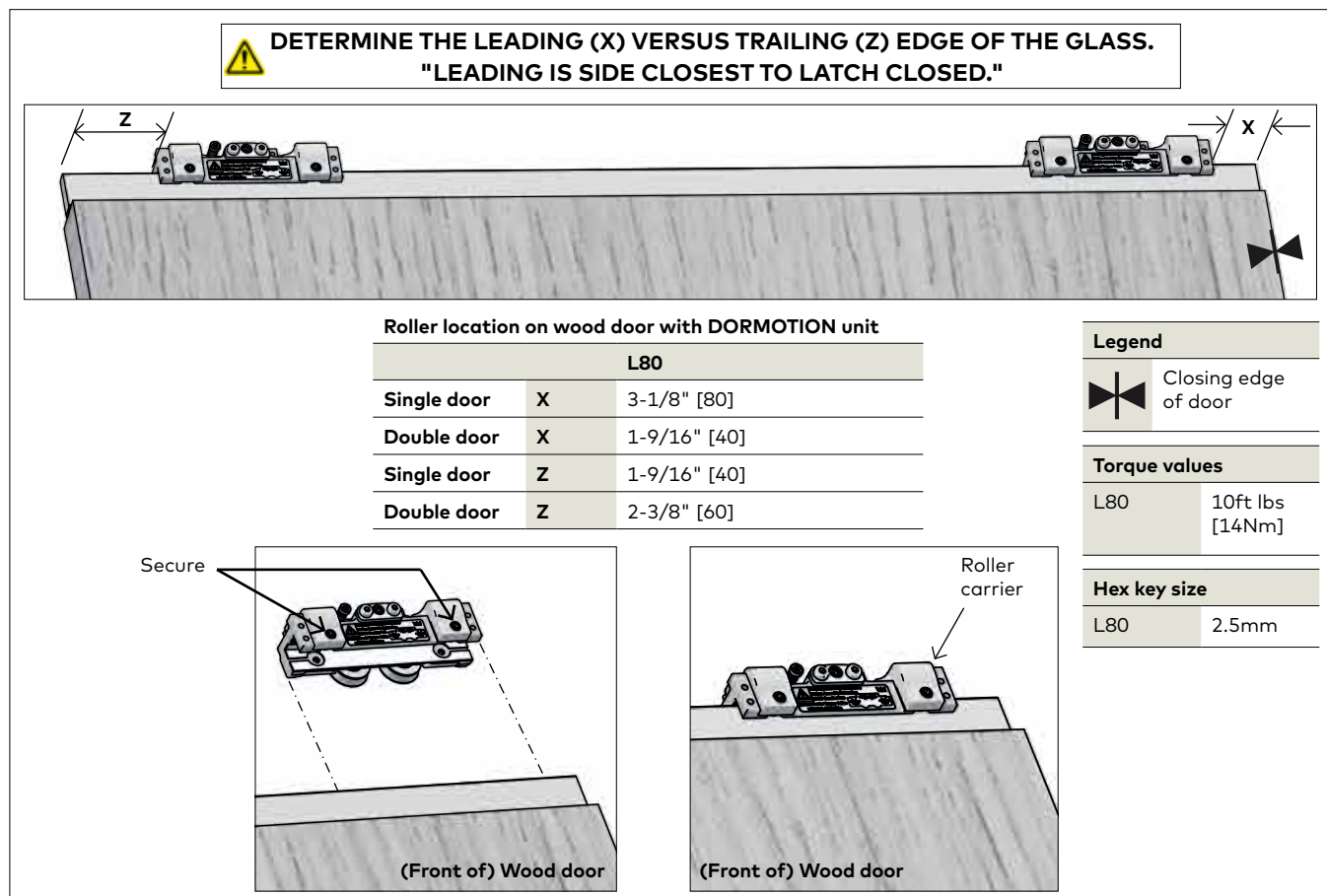

NOTE: FULLY CLEAN SURFACE OF ADAPTOR WITH AN ALCOHOL-BASED MILD GLASS AND SURFACE CLEANER.

ENSURE GASKET IS FREE OF DEBRIS.

ENSURE ROLLER CARRIER WHEELS ARE FREE OF DEBRIS.

- 2.5.1 Slide roller carriers onto wood door adaptor.
- 2.5.2 Slide gasket and metal shim between adaptor and roller carrier.

NOTE: Orient with gasket facing the adaptor.

- 2.5.3 Secure roller carriers to wood door adaptor using appropriate-size hex key at 10ft lbs (14 Nm).

2.6 Install DORMOTION start/stop

Fig. 4

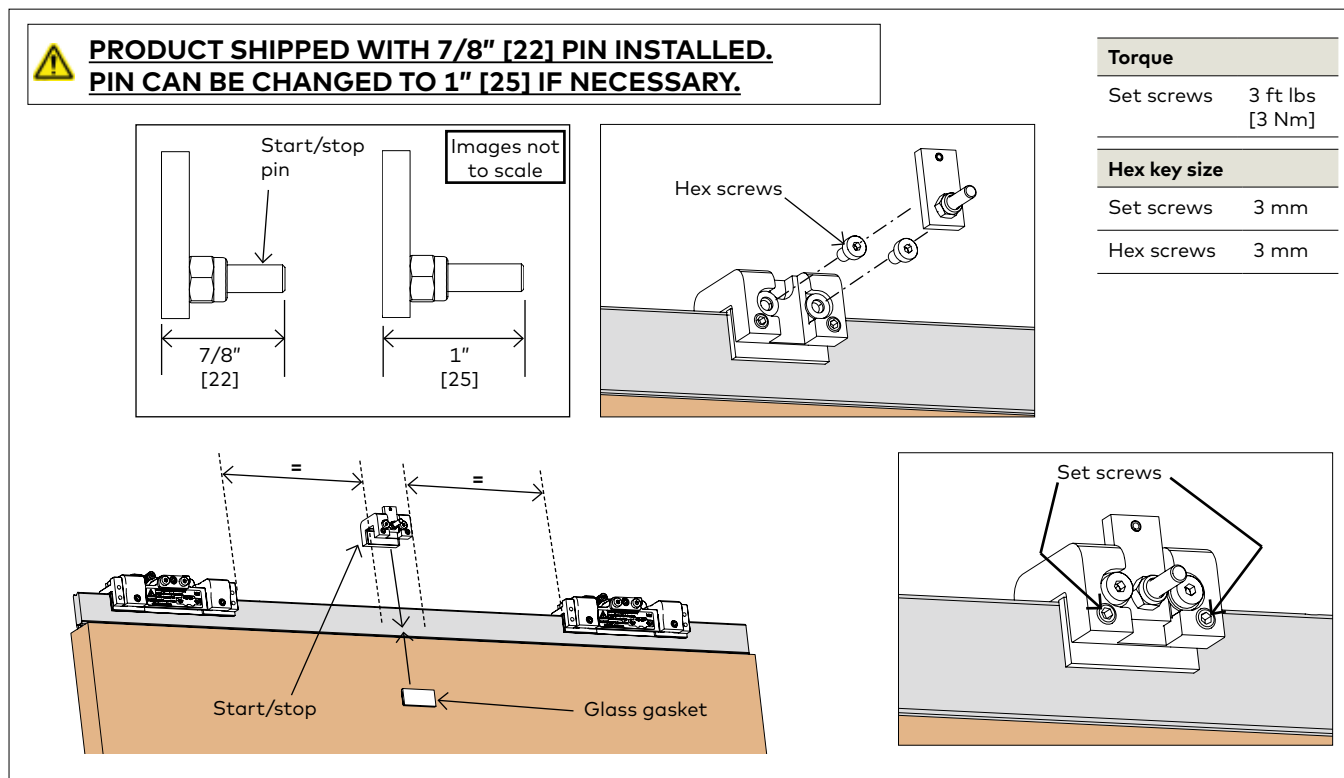

NOTE: Determine a pin length based upon how square and plumb the opening is.

2.6.1 If required, change pin in start/stop assembly.

- Remove hex screws.
- Remove existing pin and plate.
- Swap in appropriate pin and plate.
- Replace hex screws.

2.6.2 Slide start/stop onto glass.

2.6.3 Center equally between the carriers.

2.6.4 Slide glass gasket between start/stop and glass.

NOTE: Orient with gasket facing glass.

2.6.5 Secure start/stop via set screws.

2.7 Disengaging the anti-jump

Fig. 5

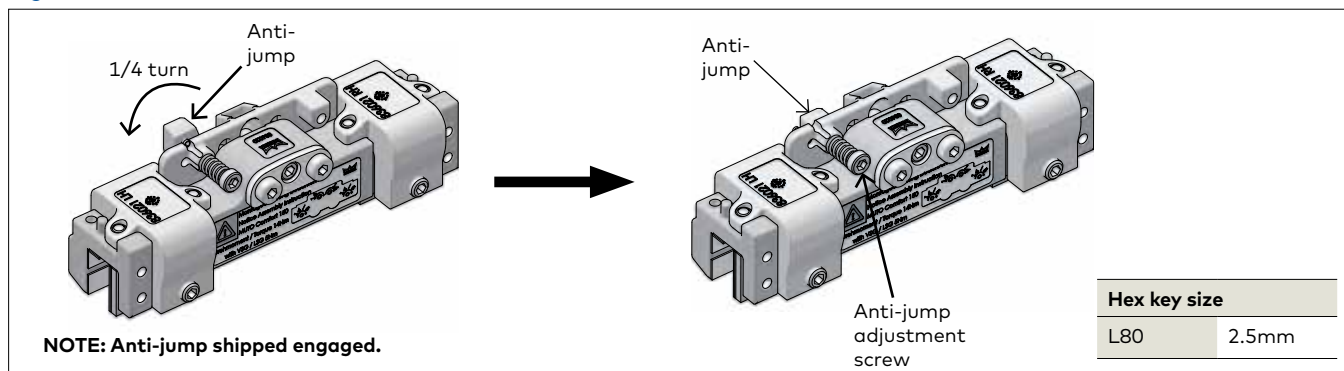

2.7.1 Disengage the anti-jump on roller carrier.

NOTE: Using the appropriate-size hex key, push anti-jump adjustment screw IN and turn **COUNTER-CLOCKWISE 90° to disengage** anti-jump.

2.8 Installing the end stops

Fig. 6

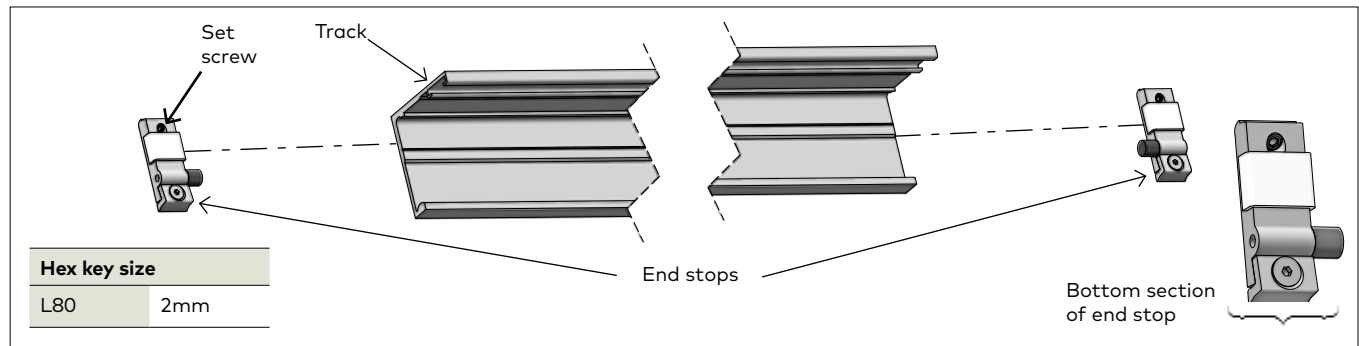

2.8.1 Slide end stops into each end of the track.

NOTE: Loosen bottom section of end stop for easier install.

NOTE: Be sure set screw is flush with back of end stops.

NOTE: Exact location/adjustments will be determined in "Adjustment End Stop Location" step.

2.9 Install door/rollers in track

Fig. 7

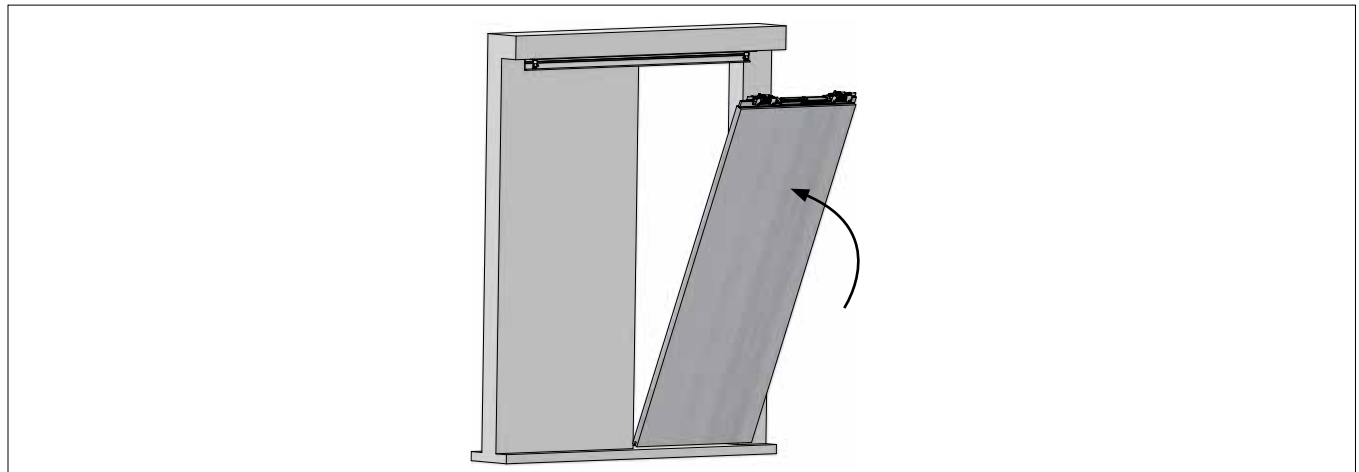

⚠ ENSURE ROLLERS AND TRACK ARE FREE OF DEBRIS.

2.9.1 Tip wood door and rollers upward and rest rollers on track.

2.10 Install floor guide

Fig. 8

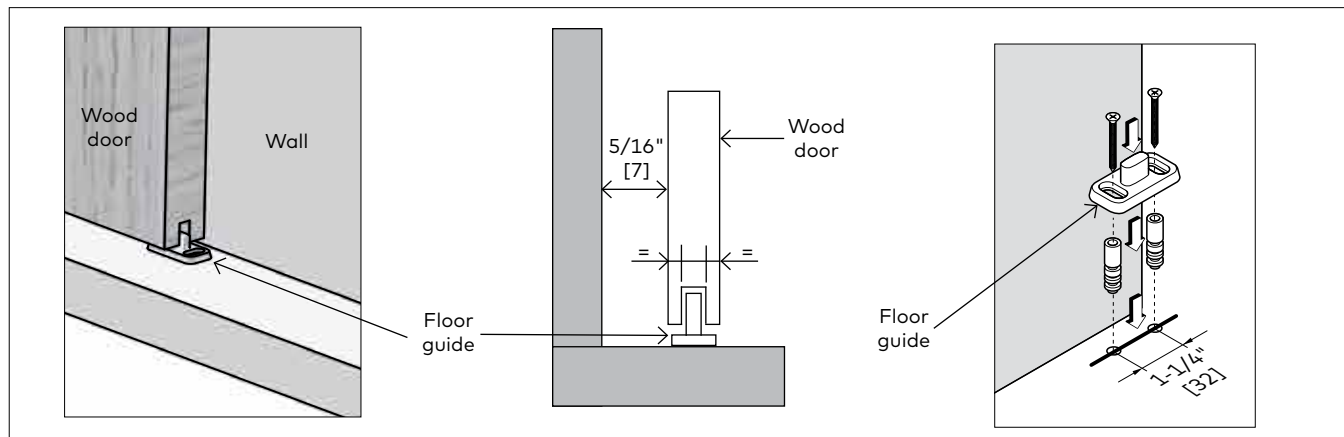

ANTI-JUMP IS DISENGAGED!

- 2.10.1 Temporarily slide floor guide into bottom groove of wood door.
- 2.10.2 Be sure door is plumb.
- 2.10.3 Mark appropriate floor guide measurements.

2.10.4 TEMPORARILY REMOVE WOOD DOOR AND ROLLERS FROM TRACK.

2.10.5 Pre-drill into mounting surface using a 5/16" drill bit.

2.10.6 Secure floor guide with included fasteners.

2.10.7 SET WOOD DOOR AND ROLLERS BACK ONTO TRACK.

2.11 Engaging anti-jump

Fig. 9

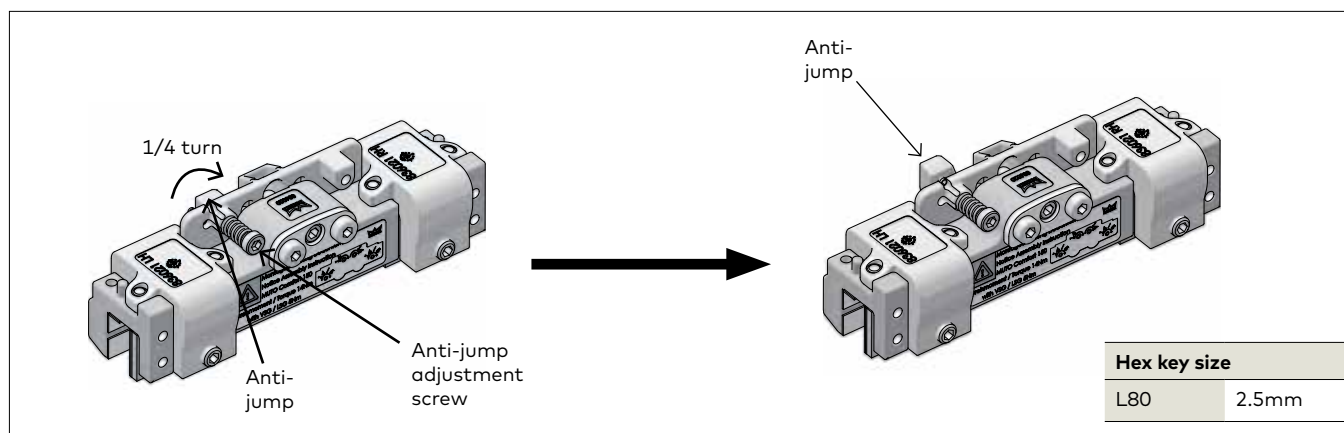

2.11.1 Engage anti-jump on roller carrier.

2.11.2 Using appropriate-size hex key, push anti-jump adjustment screw IN and turn **CLOCKWISE** 90° to **engage** anti-jump.

2.12 Adjustment door height

Fig. 10

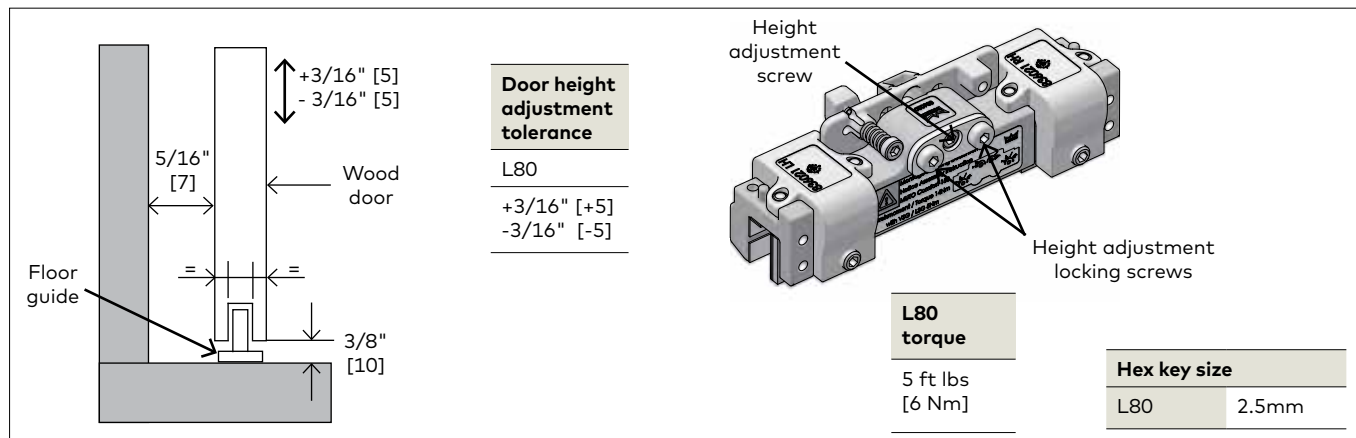

- 2.12.1 Set height of glass door.
- 2.12.2 Loosen height adjustment locking screws of carrier.

- 2.12.3 Using appropriate-size hex key, turn height adjustment screw **CLOCKWISE** or **COUNTER-CLOCKWISE** to raise or lower door.

NOTE: Be sure wood door is level during this adjustment.

2.13 Adjustment end stop location: LEADING end stop

Fig. 11

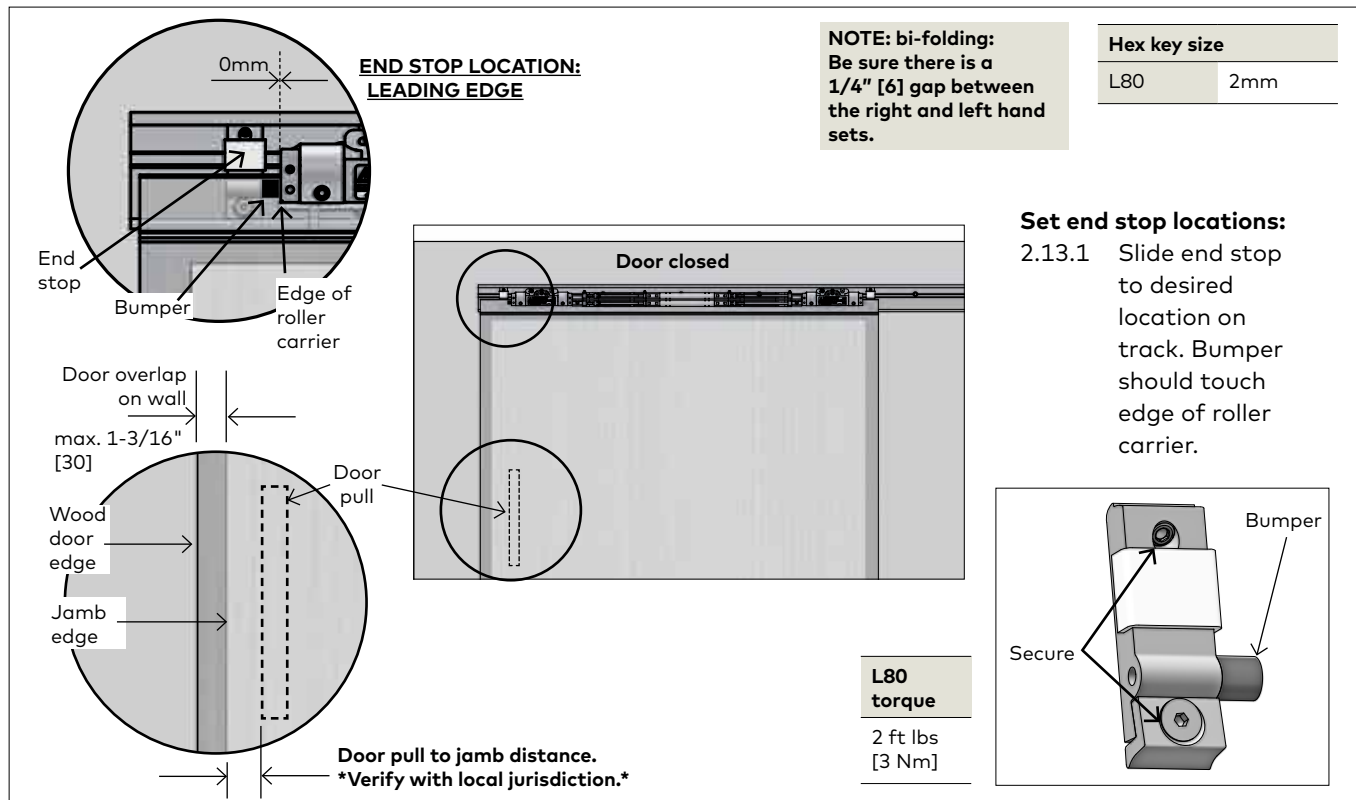

Adjustment end stop location: TRAILING end stop

Fig. 12

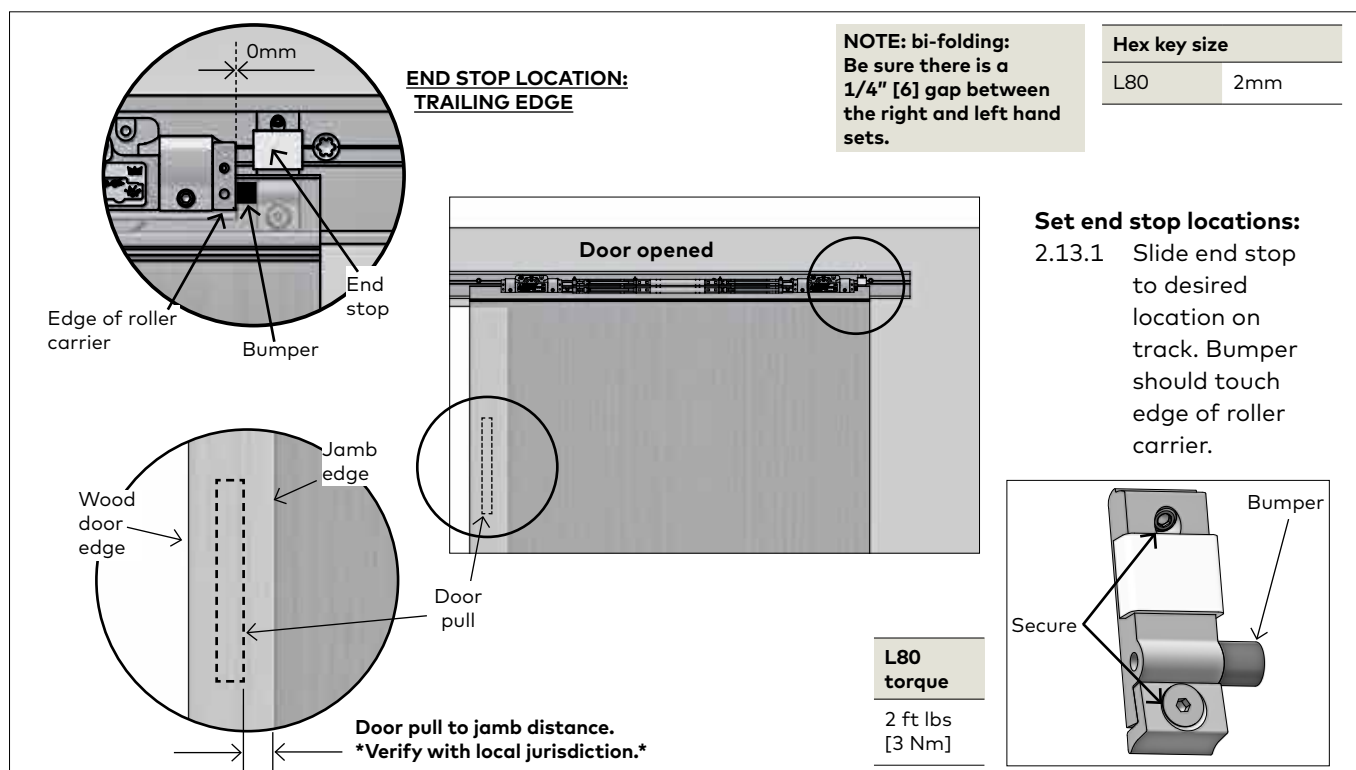

2.14 Install DORMOTION units

Fig. 13 DM unit installation

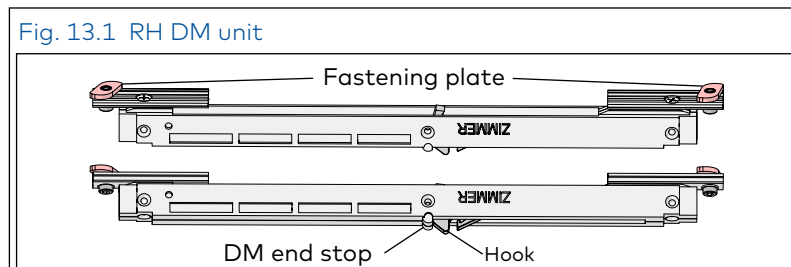

Fig. 13.2 RH DM unit fastening plates rotated

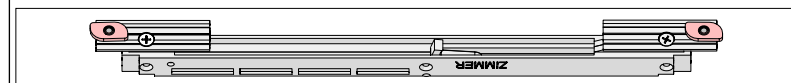

Fig. 13.3 RH DM unit inserted in track

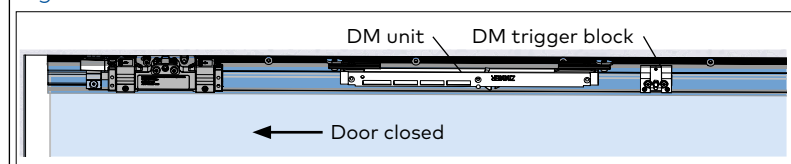

Fig. 13.4 DM unit hook positioned in trigger

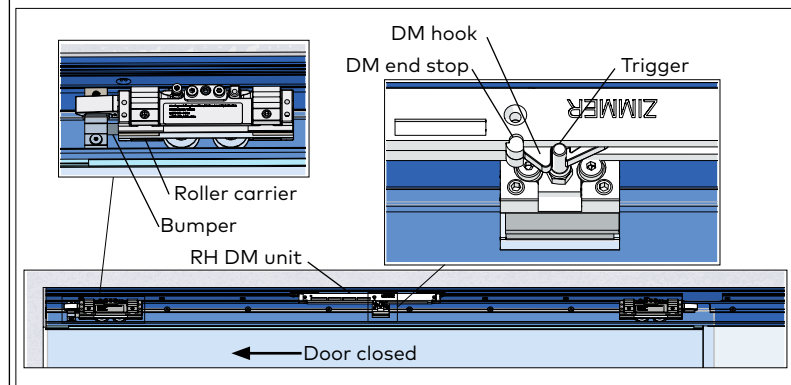

Fig. 13.5 DM unit end stop and hook separation adjustment

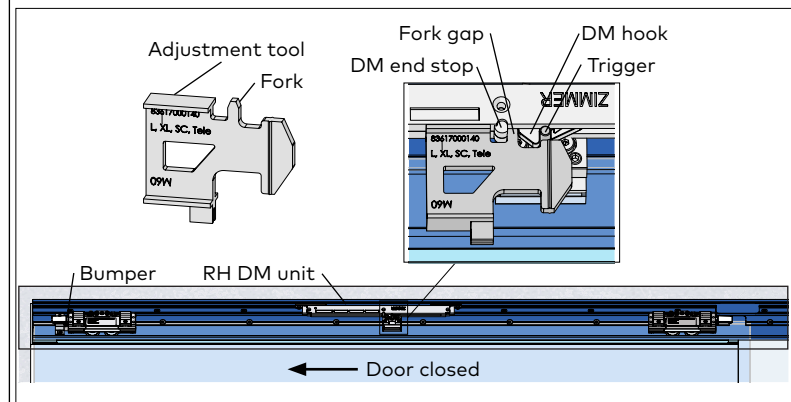
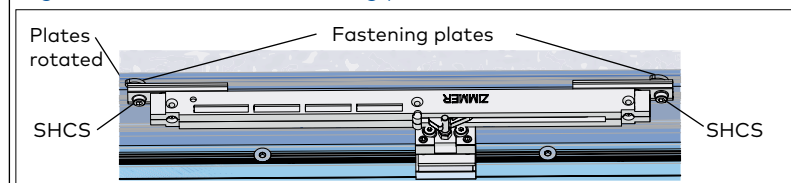

Fig. 13.6 RH DM unit fastening plates secured in track



RH Dormotion -door closed

2.14.1 Rotate RH DM fastening plates.

- Using 4 mm hex key, loosen fastening plate hex screws.
- Rotate fastening plates until they are parallel to the DM unit (Fig. 13.2)
- Snug hex screws.

2.14.2 Move door to close position.

- For installation of RH DM unit, door must be in the closed position against bumper.

Fig. 13.7 RH DM unit aligned in track

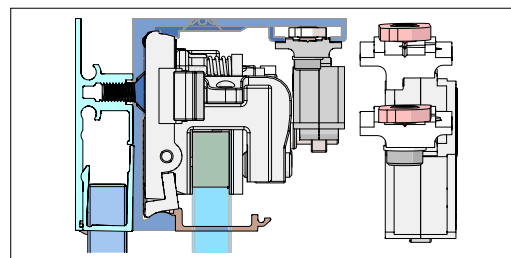

2.14.3 Align DM unit in track, engage DM hook in DM trigger.

- Align DM unit in track (Fig. 13.7).
- Slide DM unit over the DM trigger block until the DM hook engages the DM trigger (Fig. 13.4)

2.14.4 Use adjustment tool to set DM unit final position.

- Place adjustment tool flat against DM unit with fork between DM hook and DM end stop (Fig. 13.5).
- Slide DM unit over until hook and DM end stop are against the fork. This sets 5 mm gap (fork gap).
- **Trigger height:** Adjust so trigger sets on top of adjustment tool (Para. 2.15).

2.14.5 Secure the DM unit in position.

- NOTE: Insure door is fully closed against bumper before performing this step.
- Using 4 mm hex key, tighten DM unit fastening plate socket head cap screws. Fastening plates must engage the track (Fig. 13.6 and .8).

Torque

Socket head cap screws 3 ft lbs [4 Nm]

Fig. 13.8 RH DM unit installed in track

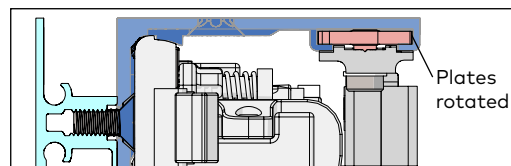

Fig. 13 DM unit installation (Con't)

Fig. 13.9 LH DM unit

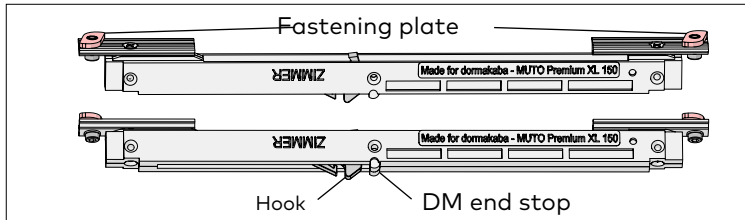

Fig. 13.10 LH DM unit fastening plates rotated

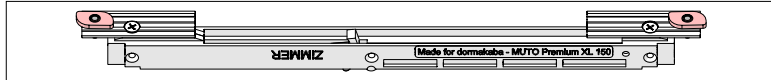

Fig. 13.11 LH DM unit inserted in track

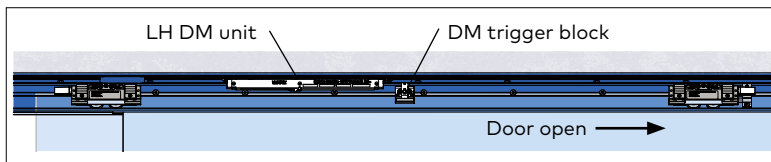

Fig. 13.12 DM unit hook positioned in trigger

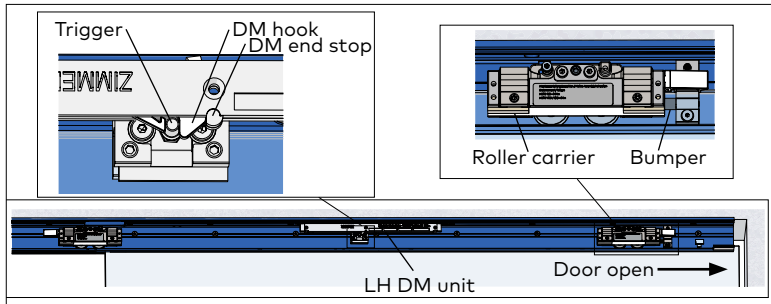

Fig. 13.13 DM unit end stop and hook separation adjustment

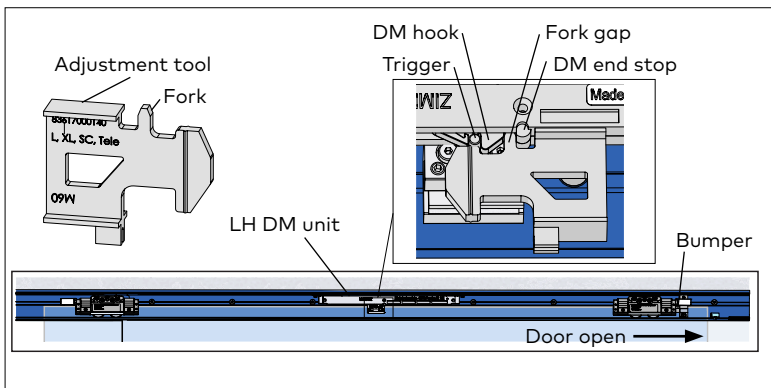
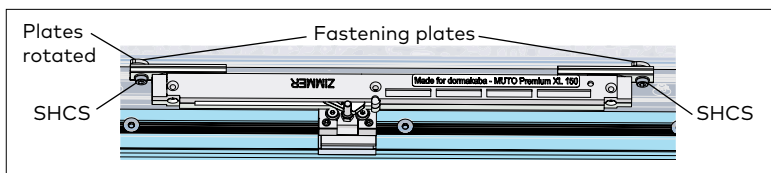

Fig. 13.14 LH DM unit fastening plates secured in track



LH Dormotion -door open

2.14.6 Rotate DM fastening plates.

- Using 4 mm hex key, loosen fastening plate hex screws.
- Rotate fastening plates until they are parallel to the DM unit (Fig. 13.10)
- Snug hex screws.

2.14.7 Move door to open position.

- For installation of LH DM unit, door must be in the open position against bumper.

Fig. 13.15 LH DM unit aligned in track

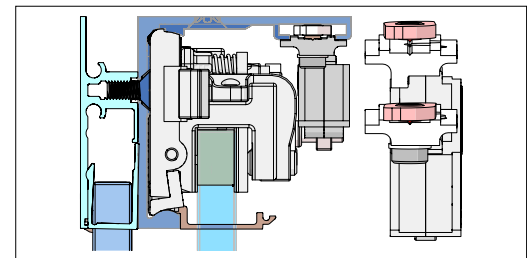

2.14.8 Align DM unit in track, engage DM hook in DM trigger.

- Align DM unit in track (Fig. 13.15).
- Slide DM unit over the DM trigger block until the DM hook engages the DM trigger (Fig. 13.12)

2.14.9 Set DM unit final position.

- Place adjustment tool flat against DM unit with fork between DM hook and DM end stop (Fig. 13.13).
- Slide DM unit over until hook and DM end stop are against the fork. This sets 5 mm gap (fork gap).
- **Trigger height:** Adjust so trigger sets on top of adjustment tool (Para. 2.15).

2.14.10 Secure the DM unit in position.

- NOTE: Insure door is fully open against bumper before performing this step.
- Using 4 mm hex key, tighten DM unit fastening plate socket head cap screws . Fastening plates must engage the track (Fig. 13.16).

Torque

Socket head cap screws 3 ft lbs [4 Nm]

Fig. 13.16 LH DM unit installed in track

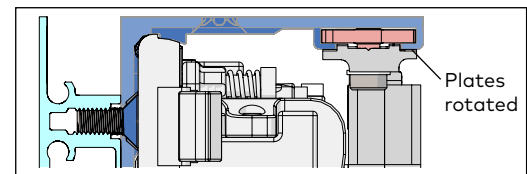

2.15 Adjust start/stop pin height (if necessary)

Fig. 14

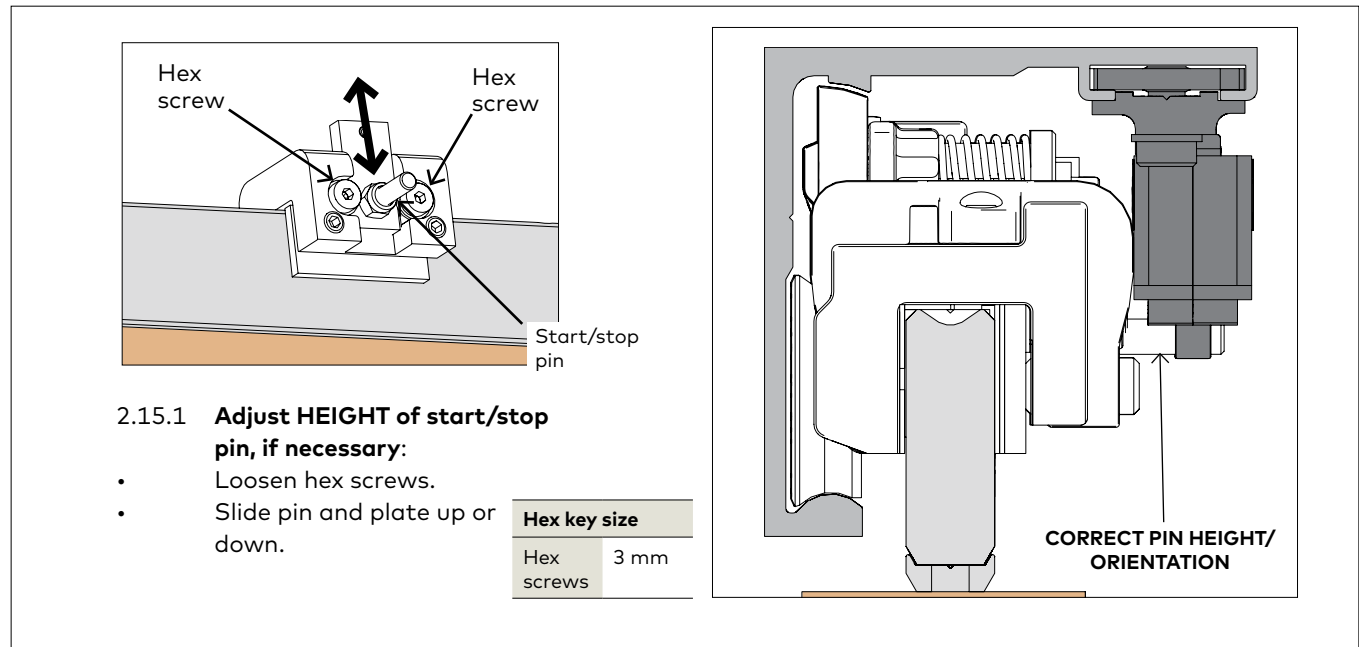

2.16 Cover clips

Fig. 15

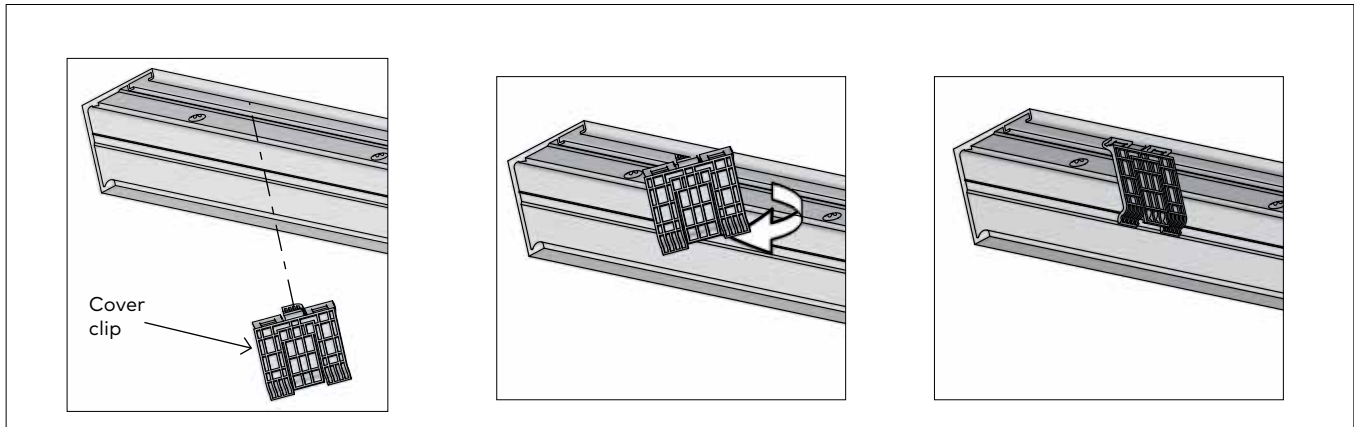

2.16.1 Insert cover clips into track. (One clip per foot)

2.16.2 Insert perpendicular to track, and turn **COUNTER-CLOCKWISE** to snap into place.

2.17 Install brush profile

Fig. 16

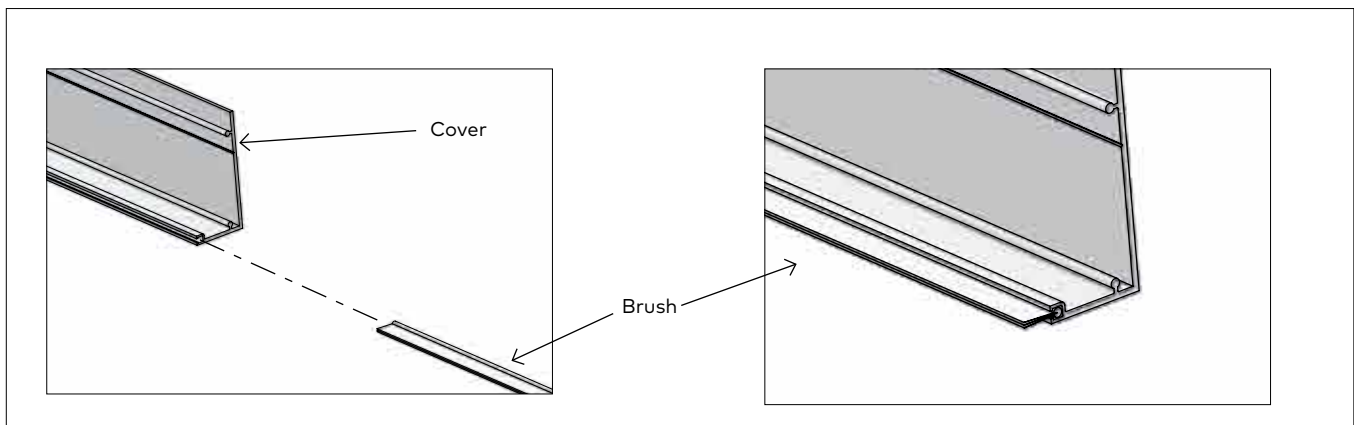

2.17.1 Measure and cut brush to appropriate length.

2.17.2 Slide brush into cover.

2.18 Install view protection clips

Fig. 17

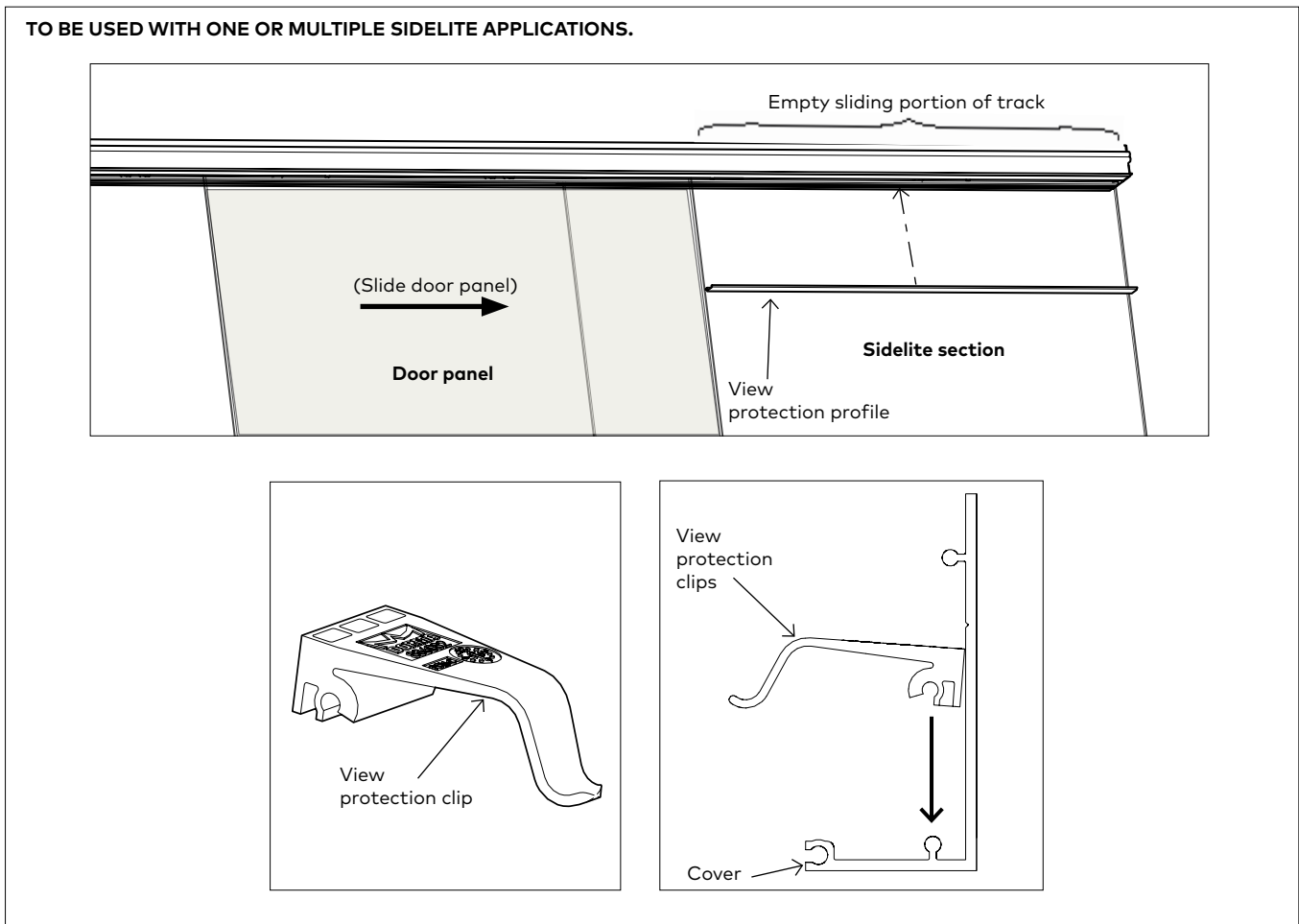

- 2.18.1 Slide door open until it meets the end stop.
- 2.18.2 Measure and cut view protection profile to fit into empty sliding portion of track - 3/16" [5].
- 2.18.3 Snap view protection clips onto inside of cover as shown.

- 2.18.4 Use minimum 1 clip per foot of profile.

Exception: If profile is minimum of 1 foot in length, use 2 clips.

2.19 Install cover and view protection profile

Fig. 18

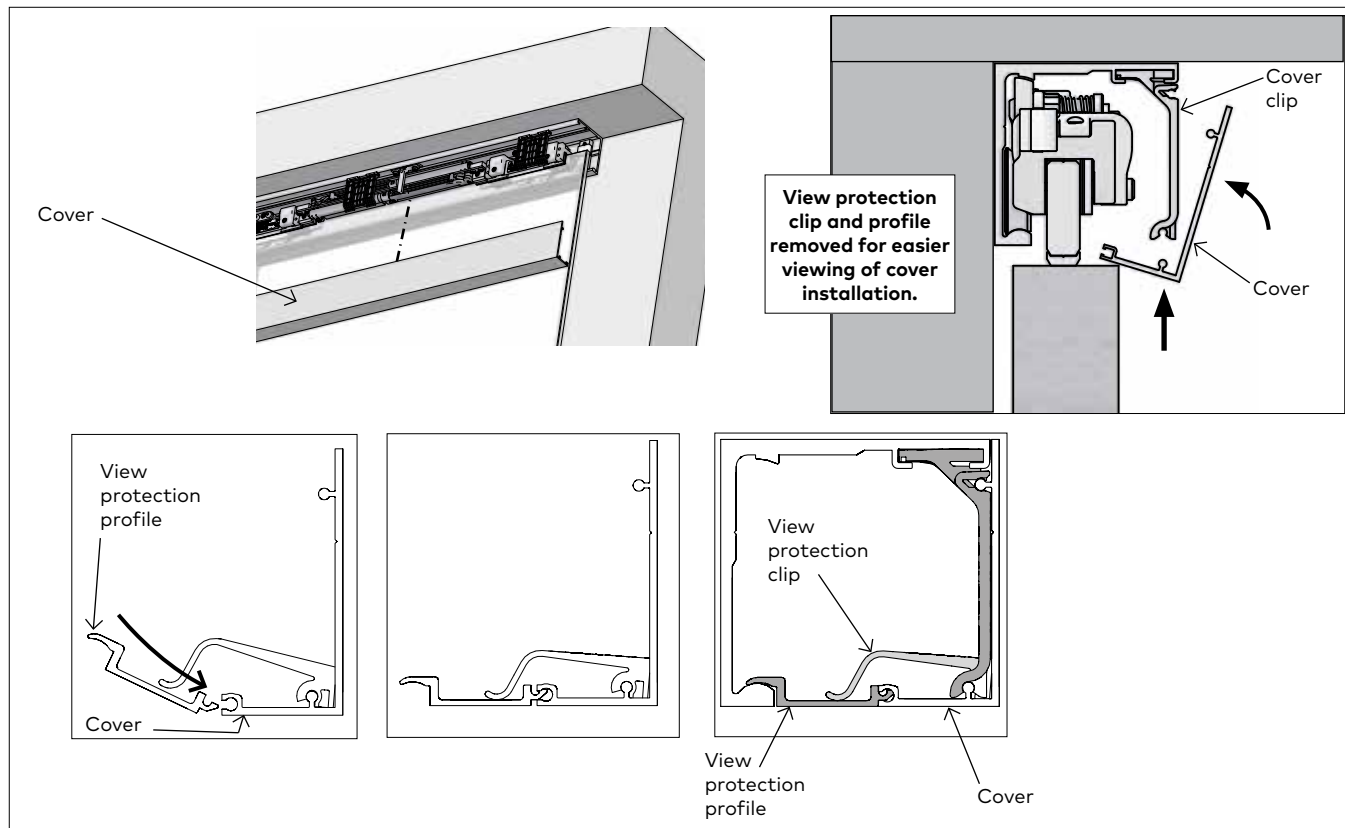

2.19.1 Secure cover to clips and snap into place.
NOTE: Roll cover from the bottom upwards. Ensure the bottom of the cover is supported by the groove in the cover clip.

2.19.2 Tip view protection profile up into track and snap down into cover and onto track as shown.

2.20 Install end caps

Fig. 19

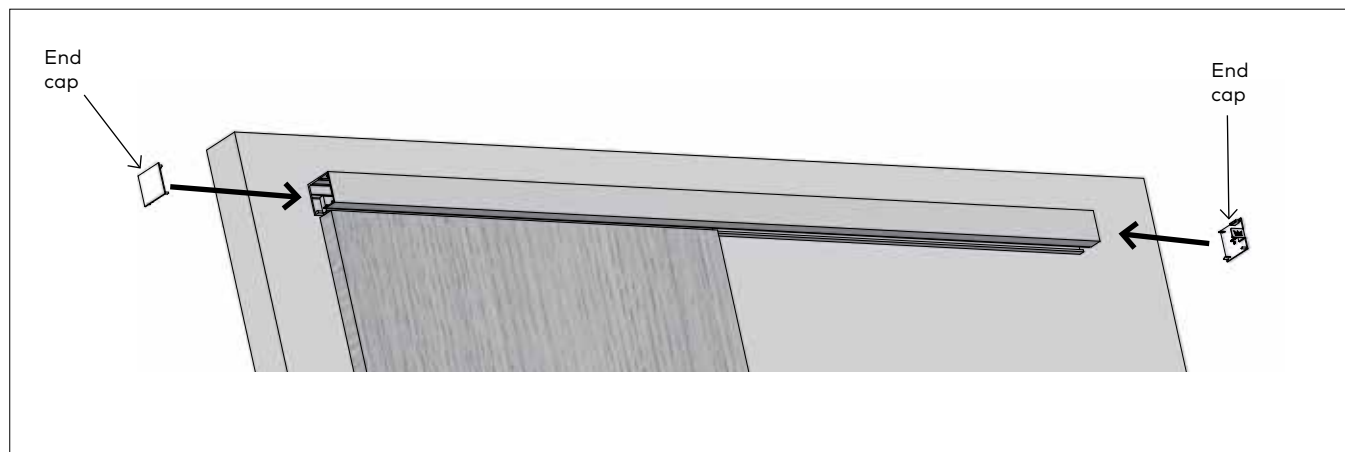

2.20.1 Snap end caps onto track.



Scan for product details and downloads.

Call 800-523-8483 or visit
glasstechserv.us@dormakaba.com
for assistance or warranty information

dormakaba USA, Inc.
1 Dorma Drive, Drawer AC
Reamstown, PA 17567